

BOA II: Asbestos Pipe-Insulation Removal Robot System

Industry Programs and the
Deactivation and Decommissioning Focus Area



Prepared for
U.S. Department of Energy
Office of Environmental Management
Office of Science and Technology

September 2001



BOA II: Asbestos Pipe- Insulation Removal Robot System

OST/TMS ID 148

Industry Programs and the
Deactivation and Decommissioning Focus Area

Demonstrated at
Oak Ridge National Laboratory
Oak Ridge, Tennessee
The Pentagon
Arlington, Virginia

INNOVATIVE TECHNOLOGY

Summary Report

Purpose of this document

Innovative Technology Summary Reports are designed to provide potential users with the information they need to quickly determine whether a technology would apply to a particular environmental management problem. They are also designed for readers who may recommend that a technology be considered by prospective users.

Each report describes a technology, system, or process that has been developed and tested with funding from DOE's Office of Science and Technology (OST). A report presents the full range of problems that a technology, system, or process will address and its advantages to the DOE cleanup in terms of system performance, cost, and cleanup effectiveness. Most reports include comparisons to baseline technologies as well as other competing technologies. Information about commercial availability and technology readiness for implementation is also included. Innovative Technology Summary Reports are intended to provide summary information. References for more detailed information are provided in an appendix.

Efforts have been made to provide key data describing the performance, cost, and regulatory acceptance of the technology. If this information was not available at the time of publication, the omission is noted.

All published Innovative Technology Summary Reports are available on the OST Web site at <http://www.em.doe.gov/ost> under "Publications."

TABLE OF CONTENTS

| | |
|--|---------|
| 1. SUMMARY | page 1 |
| 2. TECHNOLOGY DESCRIPTION | page 5 |
| 3. PERFORMANCE | page 11 |
| 4. TECHNOLOGY APPLICABILITY AND ALTERNATIVES | page 13 |
| 5. COST | page 15 |
| 6. REGULATORY AND POLICY ISSUES | page 19 |
| 7. LESSONS LEARNED | page 23 |

APPENDICES

| | |
|-------------------------------|---------|
| A. REFERENCES | page 25 |
| B. ACRONYMS AND ABBREVIATIONS | page 27 |
| C. COST DATA | page 29 |

SECTION 1 SUMMARY

Technology Summary

Problem

Most of the steam and process piping in Department of Energy (DOE) facilities is clad and insulated with asbestos-containing materials (ACM), which must be removed before any deactivation and decommissioning (D&D) activity. Manual removal is expensive and time consuming because of the carcinogenic nature of asbestos fibers and abatement regulations from EPA and OSHA. Current manual methods require substantial infrastructure for scaffolding, containment areas, and air monitoring, which results in low asbestos-removal rates. A technology is needed for the safe and efficient removal of asbestos pipe insulation.

Solution

Carnegie Mellon University (CMU) has developed a mechanical asbestos-removal system, dubbed BOA (see Figure 1). BOA can be remotely placed on the outside of the pipe and can crawl along the pipe, wetting the ACM, encapsulating and stripping the pipe, and bagging the removed insulation. Careful attention to vacuum and entrapment airflow ensures that the system can operate without a containment area while meeting local and Federal standards for fiber-count.

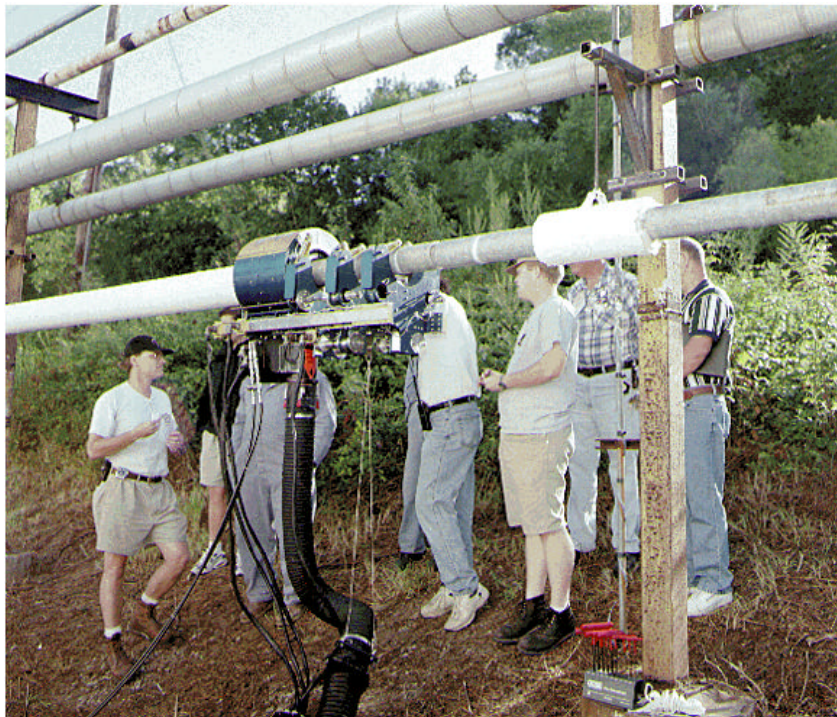

Figure 1. Initial BOA field test at Oak Ridge.

How it works

The BOA asbestos removal head is placed on the insulated pipe with the assistance of a work-positioner, while the operator controls the robot via a touch-pendant. The removal head can also be placed on pipes using a mobile boom-vehicle, allowing the system to work on pipes from 8 feet to 60 feet above ground. BOA removes insulation from pipe. BOA crawls past hangers unassisted, but requires operator assistance at obstacles such as valves. BOA cuts through various types of insulation cladding, such as plaster-tape, aluminum lagging, wire-mesh, plastic boots and pipe-clamps. BOA adapts to

varying insulation thickness, and reduces fiber emissions to allowable level while feeding

removed ACM and lagging into a vacuum-fed bagging and wastewater separator system. Lagging and insulation are cut using a hybrid endmill and water-jet cutter, and diced into 2-inch cube sections of ACM. These are removed from the pipe using a set of blasting fan-spray nozzles, and removed through a vacuum hose.

The off-board HEPA vacuum contains asbestos fibers by drawing a vacuum on the entire removal module. A separate fluid system provides sealant to spray the stripped pipe with an encapsulant material. Sensors on the removal head detect and avoid obstacles. The removed insulation sections are transported to the HEPA system where the waste and water are separated and the ACM is bagged using

standard techniques. The water is recycled for continued use in the abatement. The bagged insulation can be taken to a disposal site for treatment or disposal.

Advantages Over Baseline

- Increased asbestos removal rates
- Reduction in number of abatement personnel
- Fully contained and sealed operations
- Provides continuous asbestos removal and packaging for easy processing and disposal

Potential Markets

A thorough review of thermal insulation systems and the asbestos abatement industry within the DOE and industry was conducted (Schempf, 1995). It was determined that the DOE has about 2 million linear feet of total piping (1.5M indoors, 0.5M outdoors) of medium bore-size (4 to 8 in. DIA.) in need of abatement, collected in the six major sites (Savannah River, Hanford, INEEL, Oak Ridge, Rocky Flats, Fernald).

The industrial market size was determined to be about 33.5 million linear feet each year over the next 10 years (Schempf, 2000). BOA could abate up to 0.5 million linear feet total within the DOE and about 1.5 million linear feet a year within the industrial market segment. Assumptions are that BOA applies to 4 to 8 inch diameter piping currently abated with glovebags (22% of the total) in large installations where clearances are available for the robot to work on pipes (see Figure 2 for two conceptual deployment scenarios).

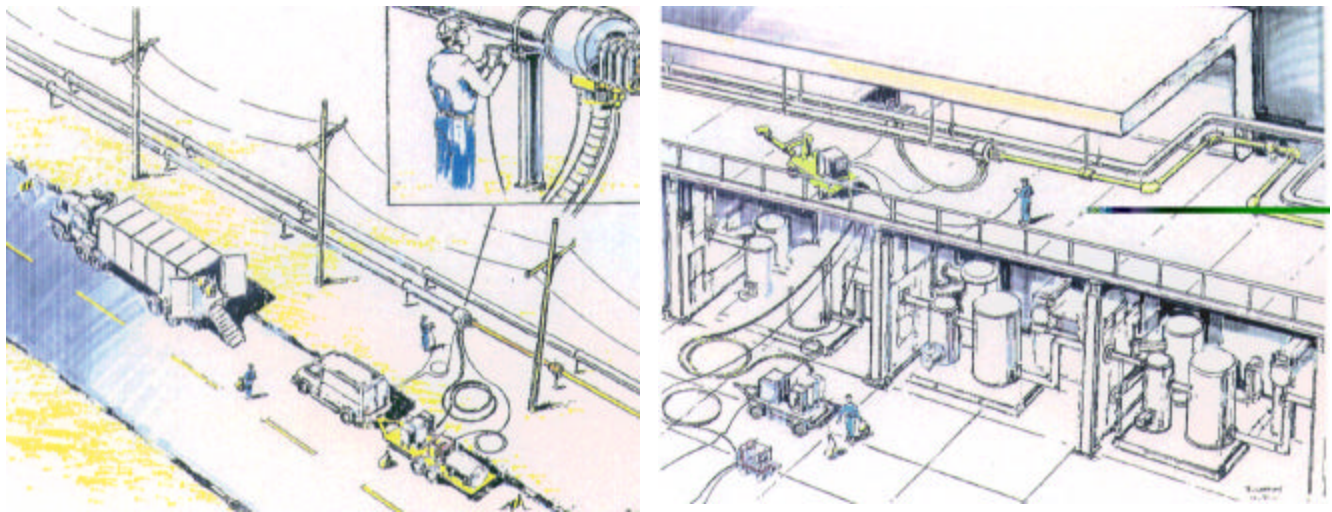

Figure 2. Conceptual deployment scenarios outdoors (left) and indoors (right).

Demonstration Summary

The first field demonstration of the BOA system was completed in August 1997 at the East Tennessee Technology Park, the former Oak Ridge K-25 Site. The system abated a 100-ft section of 4-in pipe in about 4 hours, including simple paper and mast-coated CalSil insulation with wires, passing a hanger unaided as well as removing a section of aluminum-lagged, screwed-in, wired, and banded section of insulation. Local operators were trained in the previous week, then conducted the demonstration.

A second demonstration of BOA was held at the Department of Defense's Pentagon Building in Arlington, Virginia during July 1999. Sampling conducted during site selection did not identify the canvas covering buried halfway into the insulation. As a result, testing was performed only on air cell and cheesecloth (the

only materials found during sampling). Once the demonstration began, the canvas eventually clogged the cutters and motors overheated and shorted out. It should be noted that few sites (Navy, particularly) are believed to have used canvas around insulated pipes, therefore, modifying the BOA system to handle canvas is not believed to be a high priority for future deployment.

The BOA technology placed second in a national design competition hosted by the renowned Design News trade journal/magazine. BOA was selected from a large number of national entries and was judged to be one of the most innovative new designs and products in the United States in 1997/1998.

Contacts

Technical

Hagen Schempf, Principal Investigator, Carnegie Mellon University, e-mail: hagen@frc2.frc.ri.cmu.edu, Telephone: (412) 268-6884

Management

Vijendra P. Kothari, Project Manager, National Energy Technology Laboratory, e-mail: vijendra.kothari@netl.doe.gov, Telephone: (304) 285-4579

Robert C. Bedick, Product Manager, National Energy Technology Laboratory, e-mail: robert.bedick@netl.doe.gov, Telephone: (304) 285-4505

Mark A. Gilbertson, EM-52, Program Manager, Office of Science and Technology, e-mail: mark.gilbertson@em.doe.gov, Telephone: (202) 586-7150

Web Site Locations

The Carnegie Mellon University Internet address is <http://www.cmu.edu>. The National Energy Technology Laboratory Internet address is <http://www.netl.doe.gov>.

Licensing

Noellette Conway, Automatika, Inc., e-mail: noellette@automatika.com, Telephone: (412) 968-1022

Other

All published Innovative Technology Summary Reports are available on the OST Web site at <http://www.em.doe.gov/ost> under "Publications." The Technology Management System (TMS), also available through the OST Web site, provides information about OST programs, technologies, and problems. The OST/TMS ID for BOA II: Asbestos Pipe-Insulation Removal Robot System is 148.

SECTION 2 TECHNOLOGY DESCRIPTION

Overall Process Definition

The BOA robotic asbestos abatement system is designed to remove asbestos-containing insulation from piping and place it in plastic bags for disposal, while complying with regulatory requirements and with minimal labor. This system is projected to provide faster, less expensive removal and packaging for disposal than the baseline of removal using manual labor. The only site-supplied requirements are tap water (about 50 gallons per day) and 110 volt alternating current (VAC) shore power to run the backup and emergency pony HEPA-Vac. The overall system configuration and interconnection of components of the BOA asbestos abatement system is shown in Figure 3. BOA features an abatement head that is clamped onto the pipe and moves along the pipe under its own power, while removing and wetting insulation under a negative pressure to prevent release of asbestos fibers. Encapsulant is automatically

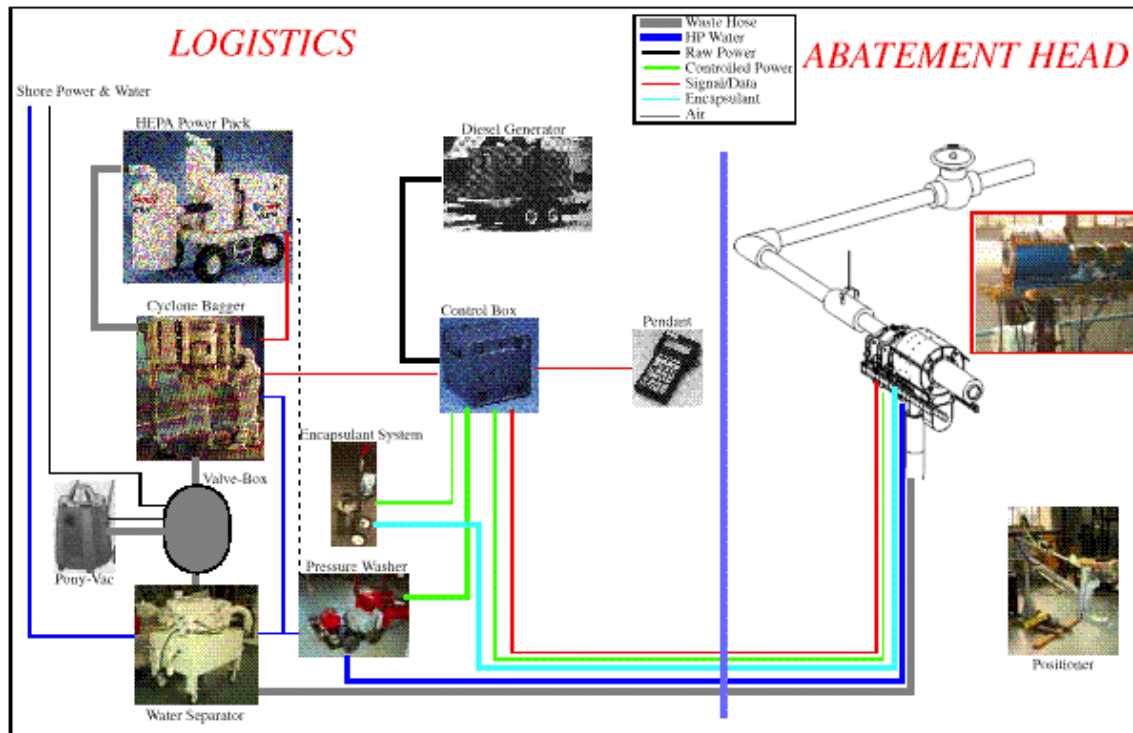

Figure 3. BOA system components and interconnection.

placed on clean pipe and short lengths of insulation that cannot be automatically removed, such as around pipe hangers and bends. Tethered to the abatement head are the off-board logistics systems to feed fluids and power and receive signals and process the waste conveyed away from the pipe. Descriptions of major BOA components follow:

Abatement Head & Positioner. The abatement head (see Figure 4) is clamped onto the pipe, and tethered to the off-board logistics support and control units via a hybrid tether. A jib-crane positioner is used to emplace and remove the abatement head on and from the pipe upon start-up and when movement around obstacles is needed. The positioner is designed to work off a floor-pallet-mounted plate for pipes at low heights, as well as a JLG-lift platform for high-reach situations.

Tether. The tether between the abatement head and the logistics unit includes power, control and feedback lines, pressurized water and encapsulant lines, as well as a 4-inch diameter vacuum hose. The vacuum hose maintains the vacuum in the abatement head, as well as serving as the conduit for the waste material. The tether is currently configured to allow up to 150 feet between the control-box and the abatement head.

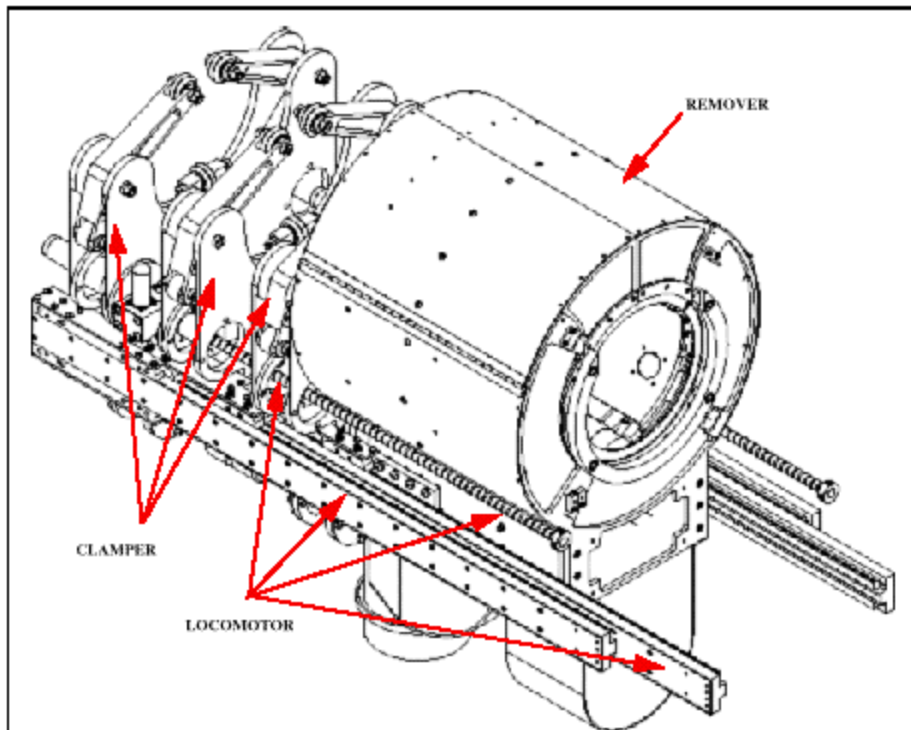

Figure 4. Three-dimensional drawing of the abatement head.

Off-board logistics. The off-board logistics are comprised of a diesel-powered electric generator, a 1,000 cubic foot per minute (cfm) industrial HEPA-vacuum system, a cyclonic waste-bagging system, and a water-separator system for removing water from the waste-stream. A pressurized water pump and encapsulant system are used to successively cut the insulation, wet the removed sections, water-blast cleaned pipe, and spray encapsulant on the pipe to trap any loose fibers. A backup pony-Vac is integrated to act as containment assurance during bag-

out, and other situations where the robot needs to be handled off and on the pipe - a valve-box takes care of switching between the pony and large vacuum pump systems.

Control Box. The control box is centrally located to efficiently control, coordinate and monitor all system parameters. The box contains all power relays and transformers, switches, amplifiers, and computing systems to operate the entire system.

Touch-Pendant. The touch-pendant serves as the interface to a human operator and is connected to the control box. The operator near the abatement head is able to monitor and control the actions of key subsystems on the machine.

Once the system is fully set up and ready to operate, there is a natural operational flow to the BOA system, which is detailed in this section. At a high level, the abatement head is responsible for removing the insulation from the pipe without any human assistance, while the off-board logistics systems supply it with the necessary fluids and power/control to do the job. The description below assumes that all equipment has been set up and connections have been made, systems have been primed and checked out, the abatement head has been removed from its travel case and placed onto a pipe and is ready for abatement.

The diesel generator supplies all the necessary power to the system, via the control box. From there, it controls power and fluid flow based on sensor feedback from each subsystem, as well as input commands from the operator pendant. The HEPA power pack is the actual source of vacuum that is used to contain fiber emissions and convey the waste material - it runs all the time and is connected to the system from a remote location (next to the generator). The cyclone bagger takes care of collecting all the dewatered waste material and upon filling up its reservoir, is used to fill waste bags using a single operator. In the case of bag-out, the robot is stopped, thereby generating no waste flowing through the system, allowing the large vacuum to be by-passed while the waste is augured into the waste-bag. During this 30-second operation, a pass-by gate in the valve-box is actuated, and an auxiliary pony-vac is used to maintain negative pressure and positive airflow through the abatement head, the waste/vacuum hose, as well as all asbestos-contaminated systems. Once bag-out is completed the system switches back over to the large vacuum and the abatement resumes. The water-separator system is responsible for dewatering the incoming waste-stream, thereby reducing the amount of water being bagged, and minimizing the use of water. The wastewater is passed through filters and fed back into the pressure-washer for re-use at the abatement head.

The encapsulant system provides separately controlled flows to the head, in order to encapsulate open edges of insulation as well as the cleaned pipe. The tether consists of several power lines and control/feedback cables, bundled with dual pressurized water lines (cutter fluid and blasting fluid), as well as supply and drain lines for the encapsulant. These cables are all bundled around the 4-inch I.D. vacuum/waste hose between the water-separator and the abatement head. At the abatement head, the hose attaches to the head, while all electrical and fluid lines are broken out and connected to different locations on the robot using hermetically sealed connectors and bulkheads.

The abatement head is made up of a clamper and locomotor section located in the rear end of the abatement head and a remover section in the front of the abatement head. The clamper and locomotor are used to clamp and translate the remover along the pipe. The remover contains all the cutting, spraying and encapsulation systems inside of its sealed enclosure that is under negative pressure. The remover uses an innovative endmill/water-jet cutter system to cut through lagging and insulation and creates two-inch square chunks of material that are blasted off the pipe and sucked down the waste-chute and into the vacuum/waste hose. A short spray blast is directed at the pipe after each cut, and a set of encapsulant nozzles apply encapsulation fluid to the pipe to trap any loose fibers.

The BOA operation is fully automated along straight runs of piping, including removal of all insulation and lagging. At each pipe hanger, the abatement head seals the open cut face of insulation before the hanger, steps past the hanger (while spraying encapsulant on the outside surfaces of the insulation) and initiates a new cut beyond the hanger, sealing the backward open face of insulation and continuing abatement. The short section of insulation left at each hanger can be removed manually using a standard glovebag, which is consistent with established OSHA procedures. Obstacles, including pipe bends, junctions, tees, and valves, are treated differently. The operator has to use the positioner to remove the abatement head from the pipe, and re-embed the abatement head on the pipe (after the section of insulation that BOA cannot reach has been removed manually) just beyond the obstacle, after which automated abatement can resume.

System Operation

The following is a step-by-step walk-through of the operations involved in the deployment of the BOA system. The steps are broken out in detail to highlight the operations and safeguards put in place to protect the environment from accidental fiber-release and to minimize potential for injury for the worker.

Transport to Site. The entire system fits onto a full-length towed lowboy trailer. All equipment would be transported to the deployment site without any special inspection or pre-cleaning requirements. The trailer would be parked as close as possible to the eventual deployment area.

Worker Training. In the case of certain deployment locations, such as the DOE, it might be necessary for the workers that will be doing the abatement and those that will be on site, participate in specialized training (such as HAZMAT, RadWorker I, II, etc.). Time can be saved if worker training is completed



Figure 5. Training for the Pentagon demonstration.

before workers arrive on site (Figure 5 shows on-site training in progress at the Pentagon demonstration).

Abatement Area Preparation. Minor preparation of the abatement area may include: clearing of any obstacles, ensuring access for the logistics systems, and installing any high-reach equipment or scaffolding needed to provide full access to all the pipes in need of abatement. A diesel generator can supply power in case site-supplied power would be difficult to provide. Running water is needed to supply wetting and cutting water to the system by first filling up the water separator, and then making up the water lost through absorption or evaporation.

Equipment Staging. The BOA system would be moved from its trailer to a site-specified dedicated staging area. All equipment is easily moveable and spacing is such that wiring and hoses can be laid out without need for special protection from vehicle or pedestrian traffic. The layout should take into consideration the location of the control box, the positioner, and pendant controller, as well as the cyclone bagger, which should be located so that bags of abated insulation waste can be removed easily for disposal. The diesel generator and the HEPA vacuum system, due to their 80dB noise-levels should be located as far away from the area as possible, with an upper limit of 300 feet.

System Hookup. Once all the major pieces of equipment have been staged, all the electrical, fluid, data/control lines as well as pneumatic lines can be laid out and interconnected. All wires and cables will be brought in spooled onto rollable cable reels, while the 4-inch diameter vacuum hose will be carried in 50-foot lengths and interconnected on site. The vacuum hose, having been used on other jobs, will have plastic plugs to seal each section off, which will be removed to mate all the necessary lengths of sections - 150 feet of vacuum hose is the as-designed length. The hose and all tether connections are made on the electronics box and the water separator, the pressure-pump, and the encapsulant system. The Pony-Vac is plugged into a separate 110VAC outlet, water is supplied to the water separator, and the pneumatic line from the HEPA Power pack to the pressure pump is established. The abatement head is rolled in its own transport case, which is opened to allow the vacuum hose and all tether connections to be made. Once all connections have been established the electronics box switches are checked for the off position, and the operators are ready to proceed to the system checkout step.

Air Monitoring - Baseline & Spot-Check. Before operations begin, air-monitoring equipment must be in place to gather background fiber-count levels and to perform required air sampling at pre-determined time intervals.

System Checkout. System checkout consists of a predetermined sequence of steps to ready the system for abatement. First, the diesel generator is started and power connections enabled to the electronics box. The HEPA vacuum system is then also started and left idling. The computer inside the electronics box is booted up and then initiates a self-test and start-up procedure, which is fully monitorable and controllable by the operator using the touch-pendant. All other systems are then powered up one by one via relays and their operation briefly checked. The computer is then brought to the point where the abatement head can be tested.

Readying Abatement Head. All functions of the abatement head are tested. The clampers are exercised and the locomotor is stroked to see that all actuators and feedback systems are operational and that the software is operating properly. The remover head goes through a mock cutting cycle, including the use of cutting water, blasting and encapsulant systems, as well as the continued use of the 1,000 cfm vacuum system. At conclusion of testing, the Pony-Vac is turned on and the HEPA vacuum is disengaged. Only when the operator is satisfied that the system has passed through all the checkout steps without errors, should the abatement head be allowed to be emplaced on the pipe.

Emplacing Abatement Head. The positioner is moved next to the abatement head and its transport case and stand, and attached to the appropriate lifting location on the head. The entire head is lifted off and out of the case, and is transferred to the location where the abatement has been scheduled to begin. A short section (<18 inches) of pipe has to be free of insulation for the clammer to attach to the pipe and begin abatement. The positioner is maneuvered, either off a pallet lift for low-down pipes or a man-lift platform for higher-reach pipes, and the head is aligned with the pipe. The clampers are engaged and the head is allowed to self-center through the clamping action. Once solidly in place, the positioner is unhooked and removed from the immediate vicinity of the head. The open doors atop the remover are commanded to close, the iris seals are shut and the 1,000 cfm vacuum system is engaged. The operator is now ready to command the system to begin abatement, using the remote touch-pendant.

Automated Abatement. Once commanded by the operator, the computer enters an automated loop to coordinate clamping with stepping, cutting, blasting, spraying and rotational movements of the cutter heads to dice and remove insulation one two-inch swath at a time. The computer monitors all operations, but it is advisable for one operator to stay near the head to monitor its operation. The operator can interrupt the abatement process at any time, by pressing the emergency-stop button atop the pendant unit. During normal operation, all cut pieces of insulation and lagging are ejected/blasted/sucked into the waste-chute and into the waste hose for eventual bagging and disposal.

Hanger Handling. The abatement head has been optimized for automatic operation along straight sections of pipe, including maneuvering around pipe hangers. Once the abatement head reaches a hanger, a frontally-mounted IR light-gate sensor and a bump-sensor would detect the presence of an obstacle. The operator is prompted to determine if the obstacle is a hanger or a larger obstruction the abatement head could not automatically maneuver around. If the obstacle is a hanger, the remover finishes any cuts on the insulation, and sprays encapsulant on the pipe and on the open and exposed face of insulation. The system is purged of mist and flyings for 30 seconds before proceeding. Once fully encapsulated, the Pony-Vac replaces the actions of the large vacuum, and the doors are opened as well as the iris-seals, and the head begins to step past the hanger, encapsulating the outside of the untouched insulation around the hanger, but without disturbing the insulation. Once the remover is past the hanger support, the doors and seals are closed again, and the large vacuum is reengaged. The cutter heads are plunged into the insulation and a set of cuts is made to clear a section of insulation for the forward clamper to step into. Once completed all clamper sections catch up to the remover by stepping past the hanger, leaving a small donut-section of encapsulated insulation behind. This small section of insulation can then be cleaned up by a separate two-man team of asbestos workers using the standard and approved glovebagging method, which should take them no more than 15 minutes, since attaching and removing the glovebag is fairly simple with a double-ended exposed section of pipe. Meanwhile, the abatement head continues on its path of high-speed straight pipe insulation abatement.

Obstacle Handling. When the abatement head contacts an obstacle with its bump-sensor, and the operator indicates on the touch-pendant that the head cannot automatically move past it, the abatement head must be removed and re-emplaced on the pipe beyond the obstacle. This implies that a cleared section of pipe has to be made (using a standard glovebagging approach), before such reemplacement can take place. Once the cutting head completes its final cut at the obstacle, the remover will back up and blast-clean and encapsulate the pipe and the open face-cut of the insulation, and purge the entire enclosure. Once the purge is complete, the main vacuum system is shunted to the small Pony-Vac, which ensures positive airflow into the remover section, avoiding any release of potentially loose asbestos-containing fibers. The operator is prompted to attach the positioner to the robot, open the remover doors and iris seals, and in series command the clamps to open, letting the positioner take the weight of the head. The positioner is then moved to the section beyond the obstacle. Once near the cleared section of pipe, the head is re-aligned with the pipe, the clampers engage the pipe, doors and iris seals are closed, the main vacuum system is re-engaged and the positioner is removed. The system is then ready to receive the go-command from the operator through the touch-pendant. Once the command is received, the system resumes automated straight-pipe abatement.

Air Monitoring - Spot-Check. During the entire abatement operation, air monitors can be set up around the abatement head and the logistics systems, such as the cyclone bagger. Samples can be taken in a spot-check approach or run continuously over an 8-hour period.

Waste Bagging. All the pieces of insulation and lagging generated within the abatement head's remover section are removed from the head through the waste-hose and enter the water separator first, then the bagger. The water separator removes all water that has not been absorbed by the waste material. The cyclone bagger accumulates waste to fill its reservoir, then the operator presses a stop button to begin bag-out. The abatement head stops and the waste-line is allowed to purge, before the valve-box diverts the 1,000 cfm airflow, allowing the Pony-Vac to maintain positive air-flow through the waste-hose and the abatement head, and the cyclone system to auger out its insides into an appended 6-mil poly-bag. Once the dump has been completed, the operator disengages the stop button, the valve-box allows the large vacuum to hook up to the abatement head, and abatement resumes. The filled bag can in the meantime be twisted, goose-necked and cut off the bagger and double-bagged for disposal. A new bag will then be attached to the mouth of the cyclone dump-chute and be ready for the next dump-out. Depending on the absorption and the rate of material flow, a full 20 to 30 pound bag will be filled every 10 to 15 minutes (about a 5-foot section of pipe), requiring a single operator who would man the bagger and check the logistics units. Alternatively, a drum with an 8-mil liner could be used to reduce the number of waste bags and change-outs needed and increase overall transport and packing efficiency.

Operator Interactions. Two workers are normally needed to operate the BOA system - one to tend the off-board logistics and bagging the waste material, and a second near the abatement head to handle obstacles, monitor operation, and tend the touch pendant controller. The logistics operator simply performs routine visual checks of lights and gauges and indicators on the logistics equipment, and

routinely bags, handles bags and takes care of proper operation and material flow on the ground. The abatement head operator interactions are typically limited to when the robot encounters a fault condition, such as detection of hangers and obstacles, or some other condition out of the ordinary. At that point the display on the pendant displays a message and sounds a bell for the operator to decide on a course of action.

System Safing. At the end of a shift or day of operations, with further operations expected the following day, the system can be safed in place in order to minimize start-up time. If allowable by the local regulations, the abatement head can be left on the pipe and secured by a lanyard, after it has cleaned itself internally using the water-blasting system, and purged itself via the vacuum for a period of a minute. The Pony-Vac would be engaged, and all other logistics systems would be shut off. The entire on-pipe system could thus be kept in place and the Pony-Vac be kept running with background monitors in operation between operational shifts. Should the in-place safing not be allowable, the procedure outlined in the *System Storage/Packing* procedure will need to be followed. Notice that this procedure is more time-consuming and is not necessarily a safer approach.

System Storage/Packing. Actions needed for storage and packing focus on the abatement head and the off-board logistics systems. Abatement head storage begins by following the same steps as maneuvering the head around an obstacle, with the exception that the positioner moves the abatement head to its transport/storage case, where the system is clamped on, and all doors/irises shut and the positioner is removed. The pressurized water lines and encapsulant systems are shut off, and the fluid and electrical lines to the abatement head are disconnected on the head-end. The waste hose is disconnected from the head and the waste chute and hose are capped with sealing plugs, all while the small Pony-Vac is running. The transport case is then closed and considered sealed for transport. The off-board logistics systems are disabled in the following order: 1) the electronics box discontinues power to the pressurized pump and encapsulant systems as well as the water-separator and cyclone bagger, and the electronics box itself is then shut off, allowing the diesel generator to be turned off; 2) the waste hoses to and between these units are disconnected and capped on both ends, including the ports on these units; 3) the waste hose connecting the cyclone bagger to the HEPA vacuum pump is attached to a drum-head adapter and then a hose is run to the bottom drain line on the water-separator in order to vacuum out all the water remaining inside the water separator, including any sludges or small waste particles that may have collected on the bottom of the separator - the entire contents of the water separator are cycloned into a drum which is capped and removed for disposal as is, or for filtering before disposal of the solids inside the water; 4) the hoses are disconnected and subsequently the HEPA vacuum pump can be shut off as well.

Clearance Sample Air Monitoring. After all equipment has been removed, a final clearance air sample can be run, if needed, although only necessary for abatement jobs with fully enclosed areas. The clearance air sample could be run for the entire abatement area or for just the transport case of the abatement head.

Loading and Transport Off-Site. With all systems disabled and connections broken, the hoses and cables can be reeled up onto movable carriers and stowed on the trailer. All subsystems can then be rolled onto the trailer and hitched so that they can be moved to the next job-site.

SECTION 3 PERFORMANCE

Demonstration Plan

System functionality testing at CMU facilities used CalSil insulation on piping and steel wire wrapping and painted plaster tape and paper and aluminum cladding to simulate conditions at actual asbestos abatement projects. Results included abatement of 94 feet of insulation in 7.5 hours of intermittent operations and bagging of removed insulation, resulting in volume reduction of 4:1. Air monitoring was conducted and provided positive results, although insulation material contained no asbestos. Pipe hangers were handled as planned, with the total time to pass a hanger at three to four minutes, which was less than the expected five minutes.

System demonstration trials were conducted at the Oak Ridge K-25 site. Results included abatement of 100 feet of CalSil insulation in four hours. Based on results of the demonstration, DOE funded a follow-on phase in which the BOA was modified to enable removal of insulation from three-inch diameter pipe, more rugged motors were added, and hardened interface was implemented. Full demonstration of the BOA prototype was planned for the K-25 site, at which three-inch diameter pipe had been targeted, but the new site contractor was unable to support the demonstration, because asbestos abatement was not a high priority D&D activity.

CMU and NETL actively pursued alternate demonstration sites, but were unable to readily locate one (commercial sites required unavailable insurance coverage and DOE sites were not ready or were not engaged in any sizeable asbestos abatement activities). At that point, the International Union of Operating Engineers (IUOE), through a subcontract with the National Institute of Building Sciences (NIBS) was able to locate a large asbestos abatement activity in the Pentagon near Washington, DC, where BOA could be tested. NIBS and the IUOE participation included development of training manuals and safety data sheets, performing air monitoring, measuring abatement rates, and developing costing guidelines. The selected site was located in the ground floor of the outside ring in the southwest corner (also called the Wedge) of the Pentagon. The full scope of the project included the abatement of all asbestos (walls, floors, ceilings, piping, etc.) in the Pentagon over a 10-year period as part of the Pentagon Renovation program.

Site Description

The demonstration site was a high ceiling indoor area, with 2 sets of 200 foot long pipe-runs hung from the ceiling with hangers at a height of about 15 feet. The insulation was tested and shown to be aircell (15% ACM Chrysotile), with a cheesecloth and paint covering (actual abatement would reveal that the sampling locations' lagging was different from the entire rest of the run, which was covered with heavy-duty canvas-cloth which greatly hampered the deployment of BOA).

Training and Abatement

The entire abatement area was to be enclosed and under negative pressure. Air samples were planned at various points throughout the abatement area, near any of the abatement equipment, and for workers operating the system. The asbestos abatement contractor's workers took care of setting up the abatement area in terms of clean-up, enclosing the area with plastic sheeting, and installing and running the negative-pressure air-exchange machines. Stationary air monitoring equipment was set up and run by an outside contractor, including monitoring of the abatement crew.

The crew was trained over a period of 3 days in the use and handling of the abatement head and off-board equipment. A short run of pipe with cheesecloth over cardboard paper, replicating the insulation to be removed by the BOA system (based on a sample taken in May 1999), was used to train the operators. As part of that training, multi-shift crews (a total of 8 people) were familiarized in the use of the equipment.

The off-board equipment was also set up inside the enclosure, except for the computer-enclosure, which was taken and placed outside of the enclosure for monitoring purposes.

Once training and public relations activities were completed (news reporting coverage, demonstrations for Pentagon officials, etc.), the system was installed on the asbestos-clad pipe run and readied for abatement. Background air samples were taken the night before abatement was to begin.

Results

Sampling conducted during site selection did not identify a canvas covering buried halfway into the insulation. As a result, pre-demonstration testing was performed only on air cell and cheesecloth (the only materials found during sampling). Once the demonstration began, the canvas eventually clogged the cutters and motors overheated and shorted out.

The BOA system was not able to fully cut the canvas, as its cutters had not been designed for this task. The BOA system made very slow progress and frequently required worker assistance. During hang-ups, water entered the on-board amplifiers and shorted them out and encapsulant leaked into the unprotected motor and slide-assembly, thereby 'gluing' them together. The net result was that BOA became inoperable and could not be repaired on-site due to the number of required spares and the need to replace internal components for which the operators had no expertise or training. The abatement head was thus removed from the pipe, cleaned externally (wipe-down) and internally as well as possible, enclosed in a bag, and placed inside the shipping trailer on site. During the untangling of the cutters and removal and storage of the abatement head, no asbestos fiber levels were found that exceeded the 0.01 fiber/cc OSHA clearance level. This indicates that the wetting and vacuum systems were effective.

It should be noted that few sites (Navy, particularly) are believed to have used canvas around insulated pipes, therefore, modifying the BOA system to handle canvas is not believed to be a high priority for future deployment.

Because of problems handling canvas in the insulation, the demonstration did not provide verification of the performance indicated in earlier testing. However, all other testing, combined with an early cost analysis performed by CMU, indicates substantial improvement in performance over the baseline manual removal. Early testing provided a removal rate of 25 linear feet per hour (capability has been estimated to be 40 linear feet per hour) compared with about 3 to 6 linear feet per hour baseline in DOE/industry.

SECTION 4

TECHNOLOGY APPLICABILITY AND ALTERNATIVES

Competing Technologies

Use of manual labor for removing and disposing of asbestos-containing material from piping systems is the standard approach used in the asbestos abatement industry.

The use of alternative methods, rather than the standard manual abatement techniques, is fairly well known. A thorough U.S. and international patent search addressing robotic or semi-automated pipe insulation abatement systems has been completed. Although there are many existing patents that cover the automated removal of coatings from the external surface of pipes, no patents were located that dealt with the removal of “thermal insulation” (herein defined as asbestos, calcium silicate, fiberglass, or other insulating material that has a thickness greater than 1/4”). Many of the coating removal systems used water, sand, or other blast media to remove coating from pipe. Still others used mechanical means such as cutters and brushes to accomplish this task. These mechanisms are similar to those proposed for BOA, but they only apply to removal of coatings of a thickness less than or equal to 1/4”. Based on an extensive search of asbestos abatement equipment manufacturers, only two types of equipment were found that are offered as ‘mechanical automation’ alternatives for different types of abatement scenarios. They are reusable glovebags and vacuum-bagging systems.

Reusable Glovebag. This is a negative pressure containment box developed by Aerospace America, Inc. This product replaces the disposable glovebags with a reusable hard-shell emplaceable enclosure within which manual glovebag work is performed. It retails for about \$500 (compared to \$5 per glovebag for cold pipe only), and sales volume has been very encouraging (~ 2,000 units to date).

Vacuum-Bagging System. The VECLoader, built by Vector Technologies Limited, is used to vacuum asbestos from the inside of full-containment areas and bag it remotely. It is only really meant for cleanup, but could be a piece of technology that has an impact on the BOA system. It retails for about \$90,000 and as many as 25,027 units have been sold over the last 5 years.

The BOA system is actually an integration and automation of these two concepts into a single device. BOA can be considered a self-travelling, fully contained mini-enclosure wherein abatement occurs, while the waste is vacuumed away from the pipe and is bagged separately off-board.

Technology Applicability

BOA is applicable to removal for disposal of asbestos-containing thermal insulation on steam and process piping. Removal of these materials may be a pre-condition for other D&D activities and is usually a requirement prior to building demolition. DOE facilities may include radioactive process and waste materials along with or contaminating asbestos-containing insulation, prompting even more careful treatment than regular asbestos during removal, handling, and disposal. The presence of these materials makes manual removal and disposal extremely costly and highly inefficient, based on the inefficiencies resulting from implementing stringent requirements for protection of human health and safety for projects based on use of manual labor. The currently projected abatement and disposal costs for thermal insulation across the DOE complex, lies in the tens of millions of dollars, based on manual removal. Therefore, the use of a mechanical and remotely operated device, such as BOA, is warranted, due to the high costs of manual abatement. Table 1 shows the applicable piping at the six DOE sites with the greatest potential need.

Table 1. Medium bore piping in the DOE Complex (linear feet).

| DOE Site | Outdoor | Indoor | TOTAL |
|----------------|---------|-----------|-----------|
| Savannah River | 110,000 | 562,000 | 672,000 |
| Hanford | 100,000 | 300,000 | 400,000 |
| INEEL | 60,000 | 189,000 | 249,000 |
| Oak Ridge | 30,000 | 184,600 | 214,600 |
| Rocky Flats | 60,000 | 186,000 | 246,000 |
| Fernald | 70,000 | 48,700 | 118,700 |
| TOTAL | 430,000 | 1,460,300 | 1,890,300 |

Patents/Commercialization/Sponsor

The technology development contractor believes that in the field of automated pipe insulation removal systems, BOA defines the state-of-the-art to date. Automatika, Inc. of Pittsburgh, Pennsylvania has received the rights to proceed with the commercialization of BOA. Additionally, the BOA system is being redesigned as a stationary unit for removal of asbestos from cut pipe sections. This approach is being pursued under a Phase I Small Business Innovative Research project led by Automatika, Inc. The technology developer believes the stationary approach to be more readily applicable to DOE in the short term.

As the developer of BOA, CMU would recommend to DOE the following technical, operational, and procedural tasks for DOE to take the existing BOA technology into a more applied phase:

- Determine the need and applicable volume for BOA within the DOE complex at this point in time. This is an important factor, since the potential need for such a system needs to be fully confirmed and quantitatively evaluated, before a decision for further development is made.
- Improve the BOA prototype to the point where repairs and minor modifications would allow the further (more controlled) testing of air-cleanliness compliance by a commercial contractor. The goal is to generate statistically representative figures as to compliance to convince NIBS, OSHA and EPA (as well as project-responsible industrial hygienists) that the BOA system is capable of meeting the legal standards. This phase should include the developer.
- Consider modifying BOA to work on 6-inch diameter or larger piping as the technical challenges will be slightly simplified, allowing for a more rugged prototype.
- Engage a commercial partner to re-engineer the prototype to include ruggedizing features and simplifying operations and user interface so that work crews can learn to operate and maintain it in the field in a timely and cost-effective manner. This might be accomplished by way of a RFP/CRADA/SBIR/STTR or other means. The developer could serve the role of advisor or consultant to the commercial entity.
- Explore the potential for spin-off technologies applicable to different areas of asbestos abatement, whether in demolition or other surface-removal applications.

This project was sponsored by the DOE Office of Science and Technology, through the National Energy Technology Laboratory, Industry Programs.

SECTION 5 COST

Methodology

Cost information in this Section was either projected from earlier demonstrations or provided in the report *BOA: Asbestos Pipe Insulation Removal Robot System Market Study, Cost/Benefit Analysis & Regulatory Review, 1995* that included discussion of the potential market for BOA, performance based on preliminary testing, and potential cost savings compared with the baseline manual removal of asbestos from piping systems.

Once a full-scale demonstration is completed for BOA, the following job cost components will be used to compare performance and cost to a baseline approach (currently full enclosure and/or glovebagging). Capital equipment cost has not yet been projected.

Setup Cost

Equipment Staging. For manual asbestos abatement, minimal cost would be associated with equipment staging. The time and manpower for moving and setting up BOA equipment needs to be accounted for.

Enclosure Setup & Air Filtering. A major cost component for manual abatement is the need for complete enclosure around the work area. This activity costs 40% (for abatement indoors) to 60% (for abatement outdoors) of total manual abatement job cost. For BOA, such a setup should not be necessary, once sufficient safety and operational data can be gathered.

Scaffolding/JLG Lift Platform. For both manual and robotic abatement, access to remote piping locations may require scaffolding or rental of a JLG lift platform.

Operational Cost

Labor & Equipment Rental Costs. Salaries (fringe, etc.) for supervisors, project designers, managers and abatement workers is a major cost component. Additionally, costs for special equipment rental needs to be considered, such as power generator(s). The main difference anticipated between the manual and robotic approach, is that, in many situations, the robotic system will shorten the time needed to complete abatement projects (and reduce cost) due to its increased productivity.

Consumables. For BOA, major consumables are disposal bags, fluids (water and encapsulant), and protective clothing. Additionally, electricity and/or diesel fuel will be consumed during the operation of the vacuum systems and the diesel generator as well as the wetting and cutting of the insulation. Manual and robotic abatement jobs will differ somewhat in the types and quantities of consumables needed.

Compliance Cost

Air Monitoring. Whether manual or robotic approaches are used for asbestos abatement, independent air monitoring and reporting will be necessary. Air monitoring costs are assumed to be the same for either approach.

Final Air Clearance Sampling. For most asbestos abatement jobs, a final air clearance sample needs to be taken and analyzed by an outside independent entity. This cost will be the same for both manual and robotic approaches.

Closure Cost

Internal Area Cleanup. For manual abatement, cleanup costs result from time spent for a certain manpower pool to clean up the area inside the enclosure (and the enclosure) using wet rags and encapsulant. In the case of the robotic system, some cleanup will be required, since manual abatement touch-up work is required.

Demobilization. Costs incurred relate to time spent for the abatement crew to break down and package the plastic enclosure material, remove scaffolding, and safing of all equipment used on the job. Both manual and robotic approaches incur these costs. The robotic approach may incur less cost, depending, for example, on the need for an enclosure.

Disposal Cost

Waste Transport & Burial/Interim Storage. Costs relate to the volume of waste generated during the abatement. Initial estimates show that BOA would reduce volume of waste material by a factor of 4:1.

Miscellaneous Costs. Insurance and bonding represent a significant cost to asbestos abatement contractors. Any difference in costs between manual and robotic abatement job is not known. Insight into this cost would be obtained once a contractor uses BOA in day-to-day operations, requiring insurance- and bonding-agency review of their process and operations in terms of risk and job-completion reliability.

Cost Analysis

The full-scale demonstration at the Pentagon did not provide enough useful data on which to base a cost analysis. However, the technology developer provided a thorough analysis of projected cost and performance in 1995 (BOA: Asbestos Pipe-Insulation Removal Robot System, Market Study, Cost/Benefit Analysis & Regulatory Review). The following analysis borrowed heavily from this document. Cost escalation and OMB discount factors were not applied because of the hypothetical nature of the cost scenarios presented in this 1995 report.

Early in this project, CMU predicted the rate of asbestos removal for a fully developed commercial BOA to be in the range of 20-60 linear feet of pipe per hour, based on early testing of cutting and locomotion mechanisms. Early prototype testing at CMU yielded a removal rate of 12 linear feet of pipe per hour. The removal rate achieved later in the project through testing at Oak Ridge was 25 linear feet of pipe per hour. For this cost analysis, CMU used the projected rate of 40 linear feet per hour, which assumes needed improvement is achieved prior to commercial application. Manual removal rates are about 3 to 6 linear feet per hour in DOE/Industry. Therefore, it was determined that substantial savings could be realized through the use of BOA (Schempf, 2000).

Overall abatement costs could decrease from 25% to 50%, depending primarily on whether the system replaces a current glovebag (relatively low cost) or full-containment (relatively high cost) operation. See Appendix C, Cost Data, for an example scenario using average DOE cost data collected by CMU for this project. Per-foot abatement costs currently range between \$25 and \$150 for Industry/DOE. Overall savings were thus computed to lie between \$10 million and \$15 million for DOE, which does not include potential savings due to reduced radiation exposure, work-crew reduction and insurance savings, overall worker safety and potential litigation cost savings. Potential unit sales to DOE (and/or its M&Os and subcontractors) and commercial asbestos abatement contractors were estimated to be between 150 and 300 units over the next 7 years, depending on the size of the contractor and job, as well as the final production cost of the system. An example analysis of a manufacturer's return on investment is shown in Appendix C.

A net present value (NPV) analysis was performed to compare the initial investment by an asbestos abatement contractor and other associated costs to the anticipated benefits (see Table 2). The net financial benefit from using BOA exceeds the costs over a reasonable payback period (3 years). The NPV analysis takes into consideration an initial investment (in this case, the purchase of a BOA unit) and a desired rate of return over a specified period of time. The resulting stream of payments (in this case the net cost savings yielded by BOA) is then evaluated to determine if it yields the required rate of return. A positive NPV indicates that the actual rate of return meets or exceeds the desired rate, and that the investment is favorable/beneficial. A negative NPV indicates that the investment/payback are not favorable.

Based on this analysis, productivity improvements achieved by using BOA will yield sufficient cost savings to justify purchase by a contractor (positive NPV) so long as the purchase price is less than \$125,000. CMU assumed that a contractor would require a nominal return on investment of 20% (typical of service-based industries). Investments/costs considered in this analysis include the initial purchase of BOA and

annual maintenance costs (estimated at less than \$2,000 per year). This cost stream is offset by income in the form of cost savings related to increased productivity with BOA. The value of BOA's productivity improvement was determined by comparison to the most likely alternative — hiring additional workers and performing the job manually.

Table 2. Asbestos Contractor Return on Investment Analysis (Schempf, 1995).

Assumptions/Constants: Customer ROI rate 20% (industry standard for service business)

| | Year 0 | Year 1 | Year 2 | Year 3 | Year 4 | Year 5 | Total |
|----------------------|-----------|----------|----------|--------|--------|--------|-----------|
| Investment/Costs | (125,000) | 1,705 | 1,705 | 1,705 | 1,705 | 1,705 | (116,475) |
| Income/Savings | | 44,063 | 44,063 | 44,063 | 44,063 | 44,063 | 220,314 |
| Cash Flow | (125,000) | 42,358 | 42,358 | 42,358 | 42,358 | 42,358 | 86,789 |
| Cumulative Cash Flow | (125,000) | (82,642) | (40,284) | 2,074 | 44,431 | 86,789 | |

Customer NPV: 1,397

Payback period: within 3 years

Productivity Increase Using BOA

| | <u>BOA Ownership Scenario</u> | <u>Manual Scenario</u> |
|-------------------------------|-------------------------------|------------------------|
| Boa Utilization Rate | 25% | |
| Boa Hours Use per Year | 520 hr | |
| Manual Hours/Year | 1,560 hr | 2,080 hr |
| Boa w/2 person crew rate | 40 ft/hr | |
| 2 person crew rate (manual) | 14 ft/hr | 14 ft/hr |
| Boa annual productivity | 20,800 ft/yr | |
| Remaining manual productivity | 21,840 ft/yr | |
| Total | 42,640 ft/yr | 29,120 ft/yr |

13,520 ft/yr more done using BOA Scenario

Annual Cost Differential Between BOA and Manual Scenarios

| | |
|-------------------------------|----------------|
| Annual asbestos worker wages | \$31,886 |
| Annual worker insurance | <u>\$9,566</u> |
| Total direct labor per man-yr | \$41,452 |
| Protective Equipment \$30/day | <u>\$6,000</u> |
| Total cost per man/year | \$47,452 |

Portion of man/yr saved by Boa 0.93
Annual Labor Savings via Boa \$44,063

Annual Maintenance Costs of BOA

| | |
|--------------------------------|----------------|
| Parts (.05% of purchase price) | \$625 |
| Labor (1.5 wks/yr @ \$18/hr) | <u>\$1,080</u> |
| Total | \$1,705 |

The increase in productivity that BOA yields over a purely manual scenario is also shown in Table 2. In both scenarios, two asbestos workers are present and working full time. In the BOA scenario, productivity is increased over the period of the year in which BOA is used (CMU estimated approximately 25% utilization, primarily due to the restrictions on BOA's applicability at any given site and the need to transport and schedule BOA between multiple job sites). For the remaining 75% of the year, the two asbestos workers continue to work at their normal rate; this is added to the linear footage accomplished using BOA to determine a total annual productivity of the BOA scenario.

The productivity increase from using BOA is therefore calculated (on a feet per year basis) by subtracting the standard manual productivity (2 people working for one year) from the BOA scenario productivity. In essence, by owning and operating BOA, a contractor would complete an additional 13,500 ft each year with the same two person crew. This amount of work is equivalent to what could be accomplished by another 0.93 workers per year. CMU based their evaluation on the costs to the contractor associated with the added labor. This calculation included the worker's salary and insurance (worker's compensation), and personal protective equipment which would be consumed.

CMU found that many contractors in the industry use temporary or part-time staff and do not pay fringe benefits, therefore, fringe benefits were not included in this analysis. Any additional management and support costs were assumed to be minor and were not included in the analysis (the ratio of management/support to asbestos workers is on the order of 1 to 5 and absorbing an additional worker without adding other staff appears to be reasonable). Incorporating all estimated costs (purchase of BOA and maintenance) and income/savings, CMU determined that this would be an acceptable investment (payback of the initial investment in BOA occurs within 3 years, which also fits the general requirements of most service businesses). The acceptability, and therefore likelihood that contractors will purchase BOA, is however strongly influenced by the purchase price of BOA. At a price only several thousand dollars greater than the assumed purchase price of \$125,000, the contractor will no longer achieve a 20% ROI and therefore may no longer be interested in this investment. In addition, the productivity increase achieved using BOA is also a critical variable.

If the BOA asbestos removal rate decreases significantly below 40 ft/hr then the cost savings will correspondingly decrease, thus making the NPV drop. BOA's utilization rate is also critical to the NPV result, however, CMU believes that 25% is a conservative number. Of these last two variables, utilization rate is perhaps the most important to focus on in the design of BOA: a 5% increase (i.e., achieving 30% annual utilization) will yield roughly a 20% increase in productivity, and therefore savings. Similarly, a 20% increase in productivity/savings can be achieved by a 13% increase in the BOA asbestos removal rate.

Although this analysis derived the price acceptable by the commercial abatement industry, we also performed a preliminary estimate of manufacturing costs. We determined that this price (\$125,000) is within reason, however, it is on the low end of our estimated range (\$100,000 to \$175,000). Until a more detailed design of the system is completed, more detailed estimates can not be made.

Cost Conclusions

- In-situ insulation removal at a high rate while complying with the applicable regulations is technically feasible and can be financially profitable.
- Compliance with applicable local, state, and federal regulations was not scientifically proven, yet the indications as to potential success are very strong; final confirmation through a thorough testing program is still required.
- Ideal application includes straight piping runs, outdoor environments, and large installations, whether industrial or commercial.
- Based on DOE figures, if BOA passes the air cleanliness criteria and its deployment and operational schemes are simplified, it should be able to save 20% to as much as 50% of job-cost compared to the manual baseline on the types of jobs that BOA is most applicable to.
- Additional benefits to DOE include avoidance of the human health risks associated with in-situ removal and working in radiologically contaminated areas. These benefits are not quantifiable with currently available information.

SECTION 6 REGULATORY AND POLICY ISSUES

Regulatory Considerations

Even though OSHA/EPA do not certify equipment for use in asbestos abatement jobs, they do specify system performance in terms of allowable exposure limits (which aids somewhat in system design), work practices (process of using abatement techniques and equipment) and approval processes (permitting, notification, etc.). From a design standpoint, we will have to ensure we meet the fiber-emissions level regulations at 0.1 fibers/cc - as spelled out in 40 CFR Part 61 (Code of Federal Regulations for EPA, National Emissions Standards for Hazardous Air Pollutants - NESHAPS). These restrictions imply the use of static and dynamic seals, positive airflow at all times, proper wetting and fiber-sealing and a proper deployment procedure to avoid any fiber release. The approval process for BOA would include drafting a technical performance report (must be written or approved by an on-site industrial hygienist or project designer with a Professional Engineering license), which is then submitted to OSHA Headquarters in Washington, DC for review and acceptance. This process is spelled out in 29 CFR 1926.1101 (g) (6) (Code of Federal Regulations for OSHA, Occupational Exposure to Asbestos; Final Rule). Local, state and regional EPA and OSHA officials would need to be informed of the planned use of BOA and invited to view the deployment and verify compliance.

The BOA system has received acknowledgment from OSHA as an allowable alternate method, as long as it remains within the limits set forth by all agencies regulating asbestos abatement. In order to comply with the regulations as written and in spirit, the BOA system had to comply with a set of clearly defined guidelines, the most important of which are listed below:

- Adequately wet the material and ensure that it remains wet until collected and contained or treated in preparation for disposal (40 CFR 61.145 - NESHAPS)
- Discharge no visible emissions to the outside air (40 CFR 61.145 - NESHAPS)
- Carefully lower the material to the ground and floor, not dropping, throwing, sliding, or otherwise damaging or disturbing the material (40 CFR 61.145 - NESHAPS)
- Permissible exposure limit (PELS): (29 CFR 1926.1101 - OSHA)
 - (1) 0.1 f/cc of air as an eight (8)-hour time-weighted average.
 - (2) 1.0 f/cc as averaged over a sampling period of thirty (30) minutes.
- Must use vacuum cleaners equipped with HEPA filters to collect all debris and dust containing ACM or PACM (29 CFR 1926.1101 - OSHA)
- Clearance air sample must be below 0.01 f/cc before critical barriers can be removed (Allegheny County Pennsylvania Ordinance 16782, Section 1001, representative of stringent local standards).
- Ensure proper sealing during all phases of operation to avoid the need for critical barriers.

The current BOA design integrates features that allow the system to comply with, or exceed, all of the major points listed above. The following discussion highlights BOA features that illustrate its use as a safe tool in compliance with applicable OSHA and EPA regulations.

Automated Abatement Using BOA

Setup & Checkout. During setup, all equipment is brought into the deployment area, staged and interconnected. During this time there is no fiber release and no special precautions over and above that of a typical abatement job. During checkout, testing all functions, including those of cutting and vacuuming, will be conducted and air monitoring may begin. The system will be fully operational for monitoring purposes.

Handling Interrupts. When system operation is interrupted and operator interaction becomes necessary, there are provisions for locking out potentially harming cutter and jetting systems, while having a backup vacuum system in operation to guarantee fiber entrapment in negative air environments. The operator(s) will be trained to enact remedial steps that ensure the avoidance of fiber-release and maintain the safety of the workers under all possible scenarios.

Cleanup. The abatement head will self-clean using its internal spray nozzles, with the wastewater being recirculated and filtered. The system will then internally encapsulate all surfaces and thus avoid any possibility of fiber-release after dry-up. Since the encapsulant is water-soluble, future use of the system will not be hampered.

Stowage. The abatement head has its own storage case with an internal pipe in order to allow the system to be transported in a fully sealed case without interchanges of air, while serving as the staging container where system checkout can be carried out on a dummy pipe.

Transport. Transport of the complete system occurs on a flatbed trailer where all logistics and abatement systems are strapped down and covered by a tarp to keep out the elements. The entire flatbed is towed by the contractor pickup from site to site and is outfitted with a simple ramp to allow equipment to be pushed or winched aboard and be properly secured. Since the equipment will have been internally cleaned up (abatement head), have all hoses disconnected and plugged and all other system ports closed, the system will be safe to transport anywhere without the need for any special permits or procedures.

Manual Touch-Up

For BOA automated asbestos abatement, asbestos workers are still needed to perform a minor portion of the abatement work, namely around starting locations, hangers and obstacles. A description of the effort and approach made to ensure compliance are detailed below:

Start-Up. A section of about 24 inches of insulated pipe needs to be manually cleared using a standard glovebag method. This approach is simple and can be accomplished a priori, including a layout of strategic start-up sections for the entire job. The rules, regulations, and work practices set forth by all regulating bodies apply.

Hanger Clearing. The abatement head is able to pass pipe hangers without human assistance, but it leaves about a two-foot section of unabated but encapsulated insulation adjacent to the hanger. The abatement contractor can clear this section at his leisure, since the encapsulant ensures no fiber release. The glovebag can be directly attached to the pipe on either end of the insulation, speeding up and simplifying the removal process substantially. Hanger clearing can occur in parallel with the ongoing automated abatement using the BOA system.

Obstacle Abatement. Obstacles are treated similarly to hangers, except that only the cut faces of insulation on either side of the obstacle are encapsulated. The removal process depends largely on the size and shape of the obstacles. Typical obstacles are valves, junctions, bends, and tees - typical multi-glovebag approaches would be used by the asbestos workers to clear these obstacles manually, abiding by all the established regulations and work practices. Obstacle abatement can be performed in parallel with the ongoing automated abatement using the BOA system.

Safety, Risks, Benefits, and Community Reaction

Worker Safety

BOA is designed to ensure that the human operators can use the system without concerns for their safety and those of others. Examples of safety features are:

- Start-up sequences clearly detail the proper approach and order to be used when items are deployed, connected and tested.

- All three-phase AC systems have interlocking male/female polarity connectors, rugged SOW style cabling and the proper lockout procedures. All converted power supplied to the off-board logistics and the abatement head is purely DC at low current levels and with a floating ground, obviating the need for a GFI-protected system.
- The high-pressure water system uses double-ply water-supply hoses between itself and the pump, reinforced hoses for the high-pressure fluid with a 10,000 psig bursting pressure and high abrasion resistance. Internal plumbing in the pump and the remover is purely stainless tubing, and all lines are shielded in case of pin-hole blowouts. The remover's cutting and blasting nozzles are always directed towards the pipe. When doors on the remover are opened or the cutter-heads are not engaged, a software lockout prevents the pressure-pump from being activated, should an operator decide to look or reach into the remover for any maintenance or repair purpose.
- Workers need not do any heavy lifting or handling of the head - a simple actuated power-lift or positioner system is used.
- A software lockout disables all power to the endmill cutters, cutter rotation motors as well as the pressure pump, avoiding the possibility of any inadvertent command or operation while the operator is in the vicinity of the remover.
- All portions of the abatement head carry protective shields that disallow the operator from sticking foreign objects or their fingers/hands into the working end of the machine.
- In case of a main power failure while the abatement head is still on the pipe, a backup system ensures that a negative airflow and minimal vacuum are maintained within the remover and the waste-hose and water-separator. All cutting and blasting operations are immediately stopped and the abatement head stops locomoting and stays clamped onto the pipe.
- A simple software heartbeat ensures the computer system is up and running and functioning properly. Should this regular heartbeat be lost, signaling a malfunction in the system, the entire power system to the cutters, pressure pump and locomotor/clamper systems is cut off, thereby safing the system and placing it in a standby mode.
- In the case of anomalous operation, as spotted by either of the two operators, the operators have the option to depress emergency buttons in order to halt system operation and ensure a safe stand-down condition.
- Loss of vacuum detected by the on-board differential pressure sensor immediately ceases all cutting, spraying and blasting activities, disables the pressure pump and engages the Pony HEPA Vacuum system. The locomotor and clamper are also stopped and held in place. The operator is prompted through the pendant and only after the cause has been found and the problem rectified, with the vacuum switch reading a vacuum, will the system be allowed to resume abatement.
- In case the bump- or light-curtain switch is tripped, the machine stops all abatement activities and notifies the operator through the pendant for a possible set of actions.
- Soft (electric) and hard limit switches exist for every system and ensure that no subsystem can travel beyond its predetermined range so that damage to the abatement head is avoided.
- All currents to the cutter motors and all other positioning, clamping and rotary actuator systems are monitored and thresholds are maintained in order to decide on stopping and shut-off conditions.

Community Safety

BOA use for asbestos abatement should result in community safety at least equal to, if not better than, manual asbestos removal.

Environmental Impact

BOA use should result in no additional impact to the environment over and above that of manual asbestos removal.

Socioeconomic Impacts and Community Perception

BOA use is expected to lower asbestos removal cost through high productivity, resulting in lower labor costs. Manual asbestos removal does not typically involve local labor, therefore, little socioeconomic impact would be expected. Community perception can be positive through educating the public on the benefits of automated asbestos removal.

SECTION 7 LESSONS LEARNED

Implementation Considerations

- In-situ insulation removal at a high rate while complying with the applicable regulations is technically feasible and can be financially profitable.
- Compliance with applicable local, state, and federal regulations was not scientifically proven, yet the indications as to potential success are very strong; final confirmation through a thorough testing program is needed.
- Ideally applicable piping includes long straight runs and outdoor environments or large installations, whether industrial or commercial.
- Demonstrations did not provide enough data on which to base a cost/benefit analysis compared to the baseline method of manual abatement (glovebagging vs. full-enclosure). BOA should be able to save 20% to as much as 50% of job-cost compared to the manual baseline, if BOA passes the air cleanliness criteria and its deployment and operational schemes are simplified.
- Insulation types are not a concern, but lagging materials are - the cutters need to be designed to properly cut and remove said material. While the canvas cloth imbedded in insulation was encountered at the Pentagon demonstration, use of this material is not believed to be common. The technology developer believes that a special cutter for these materials (i.e. cloth) still needs to be developed (see Figure 6 for examples of lagging and insulation materials).

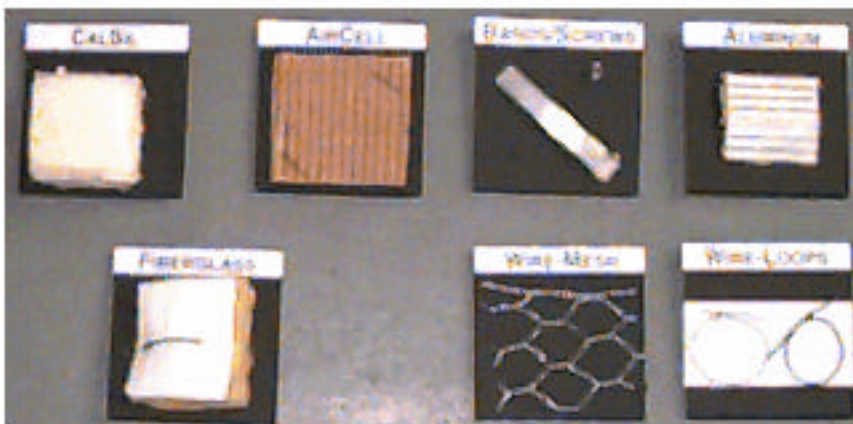

Figure 6. Samples of lagging and insulation materials.

board bagging proved itself to be technically successful yet operationally cumbersome to set up and break down and clean up.

- The hybrid endmill-waterjet cutting system was shown to be universally successful across all insulation and inflexible lagging materials, except for cloth coverings, which need to be cut differently.
- Benefits to DOE seem compelling, including potential for substantial reduction in manual labor and worker exposure.
- The impetus to use BOA within DOE seems to have been dampened by the fact that the system has had some setbacks in proving itself as viable in the prototype stage. Further, the current DOE trend appears to be simply monitoring and encasing asbestos on piping systems, rather than going for large-scale removal across the complex.

- The BOA prototype system requires some further development to fully ruggedize the unit and provide for a more user-friendly interface and simplified operations based on demonstrations and operator training sessions conducted to date.

- The concept of hybrid cutting, water-cutting/-blasting and vacuum removal and manual off-

Technology Limitations and Needs for Future Development

The technology developer recommends the following technical, operational, and procedural tasks needed for successful deployment at multiple sites:

- Verify the DOE site need and site-specific applicability for this technology to justify further development.
- Improve the BOA prototype to the point where repairs and minor modifications would allow the further (more controlled) testing of air-cleanliness compliance by a commercial contractor. The goal is to generate statistically representative compliance data to convince NIBS, OSHA, and EPA (as well as project-responsible industrial hygienists) that the BOA system is capable of meeting the legal standards. This phase should include the developer.
- Consider modifying BOA to work on 6-inch or larger piping as the technical challenges will be slightly simplified, allowing for a more rugged prototype.
- Engage a commercial partner for re-engineering the prototype to include ruggedizing features and simplified operation so that asbestos removal crews can quickly learn to operate and maintain the system. The developer could serve the role of advisor or consultant to the commercial entity.
- Explore the potential for spin-off technologies applicable to different areas of asbestos abatement, whether in demolition or other surface-removal applications.

Technology Selection Considerations

As current development is concerned, three major factors must be considered prior to selecting BOA for asbestos-containing insulation removal from piping systems:

- Diameter of piping must be in the range of four to eight inches
- Materials must be removable by BOA; insulation types are not a concern, but lagging materials are – the cutters need to be designed to properly cut and remove material present and a special cutter for compliant materials (i.e. cloth) still needs to be developed.
- For maximizing cost-effective features of BOA, piping must have sufficiently long straight runs that maintain effectiveness of BOA, while minimizing the need for manual labor.

APPENDIX A

REFERENCES

Schempf, H. 2000. BOA II: Asbestos Pipe Insulation Removal Robot System. Final Topical Report Phase II. DOE National Energy Technology Laboratory. Report of work under contract No. DE-AR21-93MC30362.

Schempf, H., J. E. Bares. 1995. BOA: Asbestos Pipe-Insulation Removal Robot System Market Study, Cost/Benefit Analysis & Regulatory Review. Topical Report Phase II. DOE National Energy Technology Laboratory. Report of work under contract No. DE-AR21-93MC30362.

APPENDIX B

ACRONYMS AND ABBREVIATIONS

ACM - Asbestos Containing Materials
BOA - Robot Name and Acronym: Big on Asbestos or denoting the african snake-like animal
CaSiil - Calcium Silicate
cfm - cubic feet per minute - units of airflow rate
CFR - Code of Federal Regulations
CMU - Carnegie Mellon University
D&D - Deactivation & Decommissioning
DIA - Diameter
DOE - Department of Energy
ER&WM - Environmental Restoration and Waste Management
FERMCO - Fernald Environmental Restoration & Management Co.
FETC - Federal Energy Technology Center
GFI - Ground-Fault Interrupt
HAZMAT - Hazardous Materials
HEPA - High-Efficiency Particulate Air (Used in conjunction with filters/vacuums, etc.)
IH - Industrial Hygienist
INEEL - Idaho National Engineering and Environmental Laboratory
IR - Infra-Red
JLG - Trade-Acronym for a man-lift company
K-25 - Denomination of the Gaseous Diffusion Plant near Oak Ridge, TN
M&O - Managements and Operations
micron - one-millionth of a meter - equates to 0.00004 inches
mil - thousands of an inch
NESHAPS - National Emissions Standards for Hazardous Air Pollutants
NIOSH - National Institute for Occupational Safety and Health
O.D. - Outside Diameter
OEM - Original Equipment Manufacturer
PAPR - Powered Air Purifying Respirator
PELS - Permissible Exposure Limits
poly - Polyethylene
psig - pounds per square-inch gauge (absolute pressure units)
RTDP - Robotics Technology Development Program
SOW - Statement of Work
TIS - Thermal Insulation Systems
TWA - Time-weighted Average
Vac - Vacuum
VAC - Voltage - Alternating Current
VEC - Short Acronym for Vector Technologies Limited Product-line

APPENDIX C COST DATA

Example cost savings calculation based on average DOE case study data (Schempf 1995).

| | MANUAL ABATEMENT | ROBOTIC ABATEMENT |
|--|-----------------------------|------------------------------|
| Removal Costs (Asbestos Workers only) | 12.45 \$/ft | 1.70 \$/ft |
| Set-Up Costs (Carp. & Laborers only) | 18.96 \$/ft | 18.96 \$/ft |
| Radiation Exposure Costs (Asbestos Workers & Carpenters only) | 0.00 \$/ft | 0.00 \$/ft |
| Operator Costs | - | 3.04 \$/ft |
| Tender Costs [assisting BOA at hangers(abatement) & obstacles(handling)] | - | 2.77 \$/ft |
| Total Labor Costs: Asbestos Workers, Carpenters and Laborers | 31.41 \$/ft | 26.47 \$/ft |
| Total: Asbestos Worker Manhours/foot | 0.34 man-hrs/ft | 0.11 man-hrs/ft. |
| Percentage Manhour Savings (Manual vs. Robotic) | - | 63 % |
| Additional labor costs due to longer manual job | 24.10 \$/ft | - |
| Additional Exposure Costs due to longer manual job | 0 \$/ft | - |
| TOTAL COST | 55.51 \$/ft | 26.47 \$/ft |
| TOTAL SAVINGS | N/A | 29.04 \$/ft. |
| TOTAL PERCENT SAVINGS | N/A | 52 % |

Manufacturer Return on Investment Analysis (Schempf, 1995)

Assumptions & Constants

| | |
|--------------------|--|
| Manufactured Cost: | \$56,250 (estimated) |
| Gross Margin: | 55% (industry standard for high-tech products) |
| Selling Price: | \$125,000 (calculated from gross margin) |
| Company ROI rate: | 25% (industry standard for high-tech products) |
| Net income rate: | 12% (industry standard for high-tech products) |
| Net Income/unit: | \$15,000 (calculated from net income rate) |

| | Year 1 | Year 2 | Year 3 | Year 4 | Year 5 | Year 6 | Year 7 | Total |
|----------------------|-----------|-----------|-----------|-----------|-----------|-----------|-----------|------------|
| Productization Costs | (900,000) | | | | | | | (900,000) |
| Sales in Units | | 10 | 25 | 40 | 25 | 10 | 10 | 120 |
| Sales in \$ | | 1,250,000 | 3,125,000 | 5,000,000 | 3,125,000 | 1,250,000 | 1,250,000 | 15,000,000 |
| Net Income | | 150,000 | 375,000 | 600,000 | 375,000 | 150,000 | 150,000 | 1,800,000 |
| Cash Flow | (900,000) | 150,000 | 375,000 | 600,000 | 375,000 | 150,000 | 150,000 | 900,000 |
| Cum. Cash Flow | (900,000) | (750,000) | (375,000) | 225,000 | 600,000 | 750,000 | 900,000 | |

Company NPV: 7,419

Payback period: within 4 years